

Equipment for eye care



Ingrid Mason

CBM Capacity Development Officer and Medical Advisor, PO Box 58004, 00200 City Square, Ring Road Parklands, Nairobi, Kenya.



Wanjiku Mathenge

Regional Medical Advisor, Fred Hollows Foundation.
Email: ciku@email.com

In many low- and middle-income countries, it is often the people who are poor or with a disability – or both – who find it most challenging to access and pay for health care. When people do come to us for eye care, it is therefore vital that we provide quality services efficiently and effectively.

To achieve this goal, we must ensure that our equipment is well maintained and that we have enough spare parts and consumables for it to function with minimum interruptions. To cope with the sometimes inevitable breakdowns, we also need systems that will respond quickly to carry out repairs and replace broken or worn-out parts.

Unfortunately, the survey commissioned by this journal (page 23) has shown that many eye units in low- and middle-income countries have vital equipment that is not working, often for long periods of time, and that this has affected the services offered to patients.

Equipment needs to form part of our planning for eye care. This must start when eye care programmes are being designed and should include those who will be using the equipment. Without careful planning, it is likely that our equipment will not perform optimally and might even fail completely. And without working and effective equipment, our eye care programmes will not achieve their potential.



Trainees learn how to repair and maintain a slit lamp. ETHIOPIA.

Ismael Cordero/ORBIS

Making the best out of an investment in equipment

We should critically assess whether investment in a new piece of equipment will add value to the services we offer. Does it allow the eye care team to provide a better quality service? Does it allow the team to help more patients per day? Does it help the clinician to work more comfortably (and therefore more quickly)?

The desire for sophisticated equipment should be balanced against the need for basic public health equipment such as ophthalmoscopes (as mentioned on page 32).

Ultimately, the deciding factor must be our patients. What equipment will allow the eye unit to help the largest number of patients and provide them with the best possible care?

When facing difficult decisions on a limited budget, it may be helpful to look at patient flow within the eye unit or eye care programme. Where are the longest queues, the longest delays, or the longest waiting times? These are the areas where additional investment in equipment may be of most benefit, provided everything else, including staff, is in place to support the equipment. For example, in some eye clinics there may be a queue of patients waiting to be examined at the slit lamp. One extra slit lamp may then allow the clinical staff to see many more patients per day, whereas one extra laser will not make much difference. Or in a clinic where ophthalmoscopes are shared between clinicians, a few extra ophthalmoscopes will have a similarly positive effect on patient flow.

Continues overleaf ➤

IN THIS ISSUE

- 21 **Equipment for eye care**
Ingrid Mason and Wanjiku Mathenge
- 22 **Ophthalmic equipment survey 2010: preliminary results**
Daksha Patel, Elizabeth Mercer, and Ingrid Mason
- 26 **Equipment maintenance and repair**
DS Walia, Jane Huria, and Ismael Cordero
- 30 **Training for equipment maintenance and repair**
Sam Powdrill, Ismael Cordero, and V Srinivasan
- 32 **Donations: how to ensure you really benefit**
Ismael Cordero, Neil Murray, Henry E Nkumbe
- 34 **Purchasing equipment for an eye unit**
Catherine Cross and Philip Hoare
- 29 **EXCHANGE Multiple mobile operating tables for eye surgery** Jonathan Pons
- 36 **USEFUL RESOURCES**
- 37 **EQUIPMENT SERIES How to look after and care for a slit lamp**
- 38 **TRACHOMA UPDATE SERIES**
- 39 **CPD: TEST YOURSELF**
- 40 **NEWS AND NOTICES**



Volume 23 | Issue 73 | September 2010

Editor

Elmien Wolvaardt Ellison editor@cejournal.org

Editorial committee

Nick Astbury
Allen Foster
Clare Gilbert
Ian Murdoch
GVS Murthy
Daksha Patel
Richard Wormald
David Yorston

Special advisor for Issue 73

Ingrid Mason

Regional consultants

Sergey Branchevski (Russia)
Miriam Cano (Paraguay)
Professor Gordon Johnson (UK)
Susan Lewallen (Tanzania)
Wanjiku Mathenge (Kenya)
Joseph Enyegue Oye (Francophone Africa)
Babar Qureshi (Pakistan)
BR Shamanna (India)
Professor Hugh Taylor (Australia)
Min Wu (China)
Andrea Zin (Brazil)

Advisors

Liz Barnett (Teaching and Learning)
Catherine Cross (Infrastructure and Technology)
Pak Sang Lee (Ophthalmic Equipment)
Dianne Pickering (Ophthalmic Nursing)

Editorial assistant

Anita Shah

Design

Lance Bellers

Printing

Newman Thomson

Online edition

Sally Parsley

Email

web@cejournal.org

Exchange articles

Anita Shah exchange@cejournal.org

Website

Back issues are available at:

www.cejournal.org

Subscriptions and back issues

Community Eye Health Journal, International Centre for Eye Health, London School of Hygiene and Tropical Medicine, Keppel Street, London WC1E 7HT, UK.
Tel +44 207 612 7964/72
Fax +44 207 958 8317
Email admin@cejournal.org

The *Community Eye Health Journal* is sent **free to applicants from low- and middle-income countries**. French, Spanish, Portuguese, and Chinese translations are available and a special supplement is produced for India (in English). Please send details of your name, occupation, and postal address to the *Community Eye Health Journal*, at the address above. Subscription rates for applicants elsewhere: one year UK £50; three years UK £100. Send credit card details or an international cheque/banker's order made payable to London School of Hygiene and Tropical Medicine to the address above.

© International Centre for Eye Health, London
Articles may be photocopied, reproduced or translated provided these are not used for commercial or personal profit. Acknowledgements should be made to the author(s) and to *Community Eye Health Journal*. Woodcut-style graphics by Victoria Francis.

ISSN 0953-6833

The journal is produced in collaboration with the World Health Organization. Signed articles are the responsibility of the named authors alone and do not necessarily reflect the policies of the World Health Organization. The World Health Organization does not warrant that the information contained in this publication is complete and correct and shall not be liable for any damages incurred as a result of its use. The mention of specific companies or of certain manufacturers' products does not imply that they are endorsed or recommended by the World Health Organization in preference to others of a similar nature that are not mentioned.

Budgeting and planning

The costs and expected benefits of investing in an item of equipment need to be carefully considered and put into a business plan by the eye unit manager before purchasing goes ahead. It is not always true that investing in a piece of equipment will improve productivity and outcomes! Developing a business plan will help the manager and team evaluate the costs and benefits in a rational and logical manner before taking any decisions.

Plan for installation, training (of users and the maintenance team), maintenance and repair contracts (where needed), procurement of essential spare parts and consumables, and the physical requirements of the equipment (space, temperature, and water and electricity supply).

The plan should contain the purchase cost and the cost of delivery, customs clearance, setup, and training, as well as yearly budgets for spare parts, consumables, maintenance, and repair.

The importance of training

The sharing of technical knowledge should become part of the eye care team's normal way of working.

It is important to assign some of the responsibility for this to an equipment person or manager who will ensure that the necessary technical knowledge is shared with both users and the equipment maintenance and repair team. Training of users and the equipment team is fundamentally important to the successful use and potential impact of equipment (page 30). In turn, those who have been trained have a responsibility to pass on their knowledge to others who need it, until everyone in the eye unit has at least a basic understanding of the equipment in use.

Relationship development with industry

Recently, some equipment manufacturers have enrolled the assistance of end-users in low- and middle-income countries to clearly outline the specifications for equipment in such environments. Another venture is the training of biomedical technicians in low- and middle-income countries in the installation, care and maintenance of their equipment.

This positive partnership between VISION 2020/IAPB consortium partners, eye care programmes, and end-users demonstrates how careful and creative thinking can benefit both end-users and equipment manufacturers.

In conclusion, if we are to meet the goals of VISION 2020, we as eye care providers must acknowledge the potential of equipment to contribute to these goals – and plan accordingly.



Ophthalm



Daksha Patel

MSc Course Director and Clinical Lecturer, International Centre for Eye Health (ICEH), London School of Hygiene and Tropical Medicine, Keppel Street, London WC1E 7HT, UK.



Elizabeth Mercer

Courses Promotion and Scholarship Administrator, ICEH.



Ingrid Mason

CBM Capacity Development Officer and Medical Advisor, PO Box 58004, 00200 City Square, Ring Road Parklands, Nairobi, Kenya.

The delivery of ophthalmic services at all levels is completely dependent on equipment: from the simple torch light to the highly sophisticated equipment used for diagnosis and treatment.

In order to achieve the aims of VISION 2020: The Right to Sight and eliminate avoidable blindness by the year 2020, it is not enough to have the right equipment available at all levels of service delivery; there has to be a good maintenance and repair support service.¹

The purpose of this equipment survey (commissioned by this journal) was to obtain an overview of the key issues and challenges faced by eye health providers with regard to their equipment.

The main objectives of the survey were:

- To identify what essential equipment was available and functional, based on the *IAPB Standard List of Equipment, Drugs and Consumables for a VISION 2020 Eye Care Service Unit* (Standard List),² and where this equipment was
- To establish how much of the essential equipment was not working, the reasons equipment was not working, and for how long equipment remained that way
- To identify the impact on the provision of eye care services when equipment did not work.

Survey methods

The Bristol Online Surveys tool was used to implement the questionnaire and to collect the data online. The questionnaire was based on the equipment in the Standard List and refined after pilot testing with the students enrolled in the International Centre for Eye Health (ICEH) Community Eye Health MSc course. The questionnaire required participants to give numerical responses and to share their comments and views.

The finalised questionnaire was circulated by email to members of the ICEH alumni

mic equipment survey 2010: preliminary results

network and the International Council of Ophthalmologists as well as to participants in the various VISION 2020 Links programmes. The survey was also made available on the ICEH website for visitors in charge of eye units to provide information. Data collection was active between 24 January and 24 April 2010. Only one questionnaire was completed per eye unit.

This simple survey was not designed to obtain a representative sample across regions or countries, but rather to capture the key trends and themes with regards to equipment.

About the participants

We received 173 responses, 55.7% of which were from training facilities (tertiary hospitals). Over two-thirds of the respondents were from Africa (Figure 1).

Figure 1. Regions represented in the survey

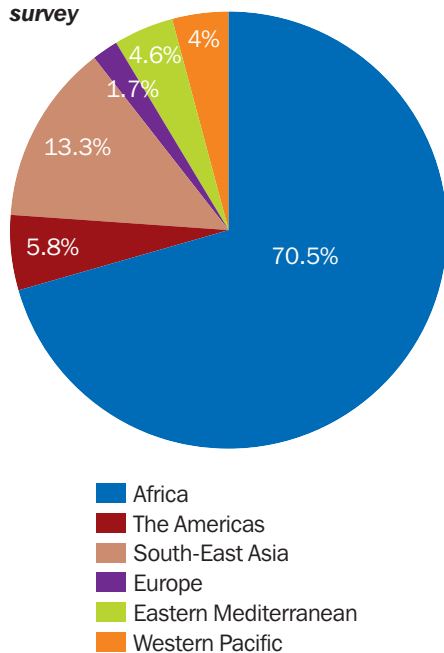

Background information on the main source of funding for each eye unit was also collected as this affects procurement of new equipment as well as maintenance and repair. Overall, half (50.9%) the responses were from government hospitals, 21.8% were from non-governmental organisations (NGOs) or mission hospital settings, whereas the remaining were either from private or insurance company-supported institutions. In Africa, 80% of all training institutions were government funded, compared to only 18% in South-East Asia.

Encouragingly, 71.1% of the eye units knew about the Standard List; this proportion was similar across the different regions.

Figure 2. Availability of equipment

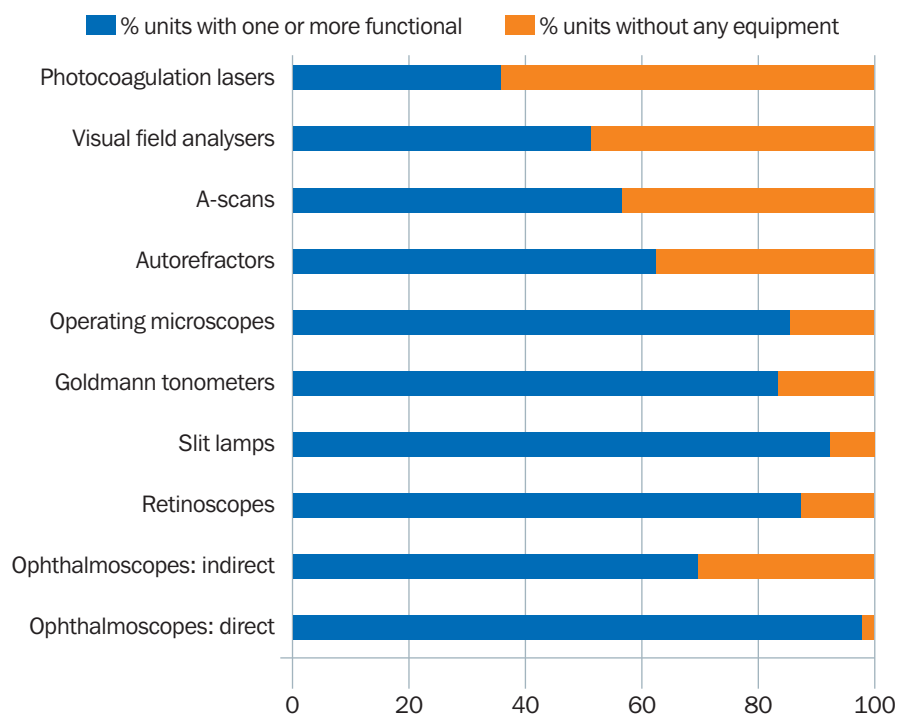

What equipment was available and working?

Overall, the private and NGO sectors were better equipped than government ophthalmic units.

This was true in all regions surveyed and across the full range of equipment covered in the survey.

Cataract surgery

In total, 80% of the units reported that, of the equipment required to provide basic cataract surgery and follow up (operating microscope, slit lamp, ophthalmoscope, and retinoscope), they had at least one that was functional (Figure 2).

However, only 57% of all units had an A-scan for carrying out biometry. Without biometry, surgeons cannot select the most appropriate intraocular lens (IOL) power and patients may need optical correction after surgery. Within Africa, only 38% of the eye units reported having a functional A-scan.

When considering training institutions separately, we found that 79.4% of the training institutions in Africa reported having no working A-scans. This was still a problem in the Eastern Mediterranean and Western Pacific regions (50% had no A-scan), but less so in South-East Asia (just 11%).

If the results can be assumed to be representative of the different regions, it is cause for concern that so few cataract

surgeons in Africa, the Eastern Mediterranean region, and the Western Pacific region have the opportunity to be trained in routine biometry.

Refractive error

Refractive error diagnosis was possible at 87% of the units who responded, as they had at least one functional retinoscope. Over 63% even had an autorefractor.

Glaucoma

Encouragingly, 78% of the units in Africa and 97% in South-East Asia reported having at least one tonometer. A total of 14% of units in Africa reported that non-functioning tonometers remained unrepaired for over a year, mainly as no one was trained to identify and manage the technical problems that occurred.

Over half of the eye care institutions responding from Africa and South-East Asia had no visual field analysers; this highlights the need to strengthen quality glaucoma management in these regions.

Equipment that had stopped working

We were interested to find out:

- In which eye units equipment had stopped working
- Why equipment had stopped working
- How long equipment didn't work for, and why.

Continues overleaf ➤

Figure 3. Percentage of eye units with one or more items of equipment that did not work (by provider)

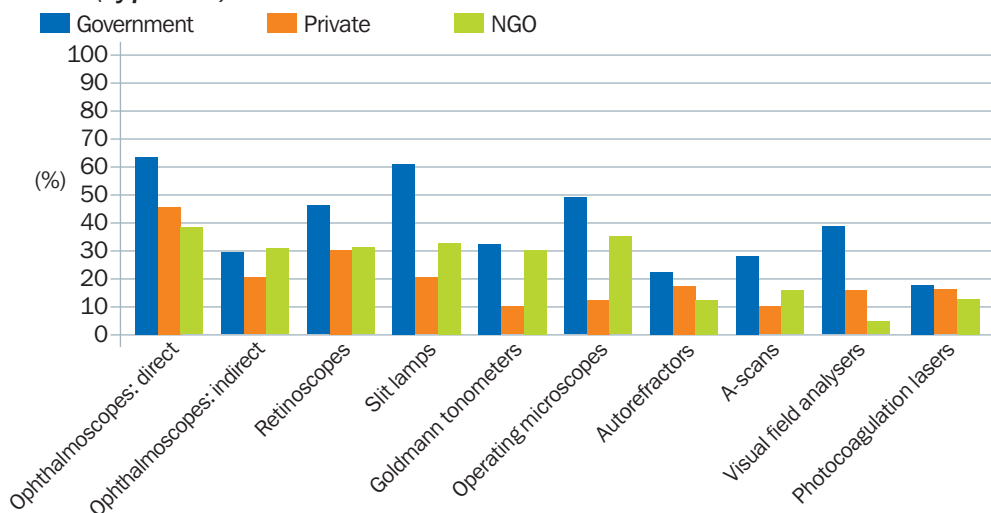

Where was the equipment?

Figure 3 highlights the challenges faced in the government sector (the main health service provider in many countries) compared to the NGO and private sectors. In all instances, more government eye units had equipment that did not work. Notably, 60% of the government units reported that one or more slit lamps did not work.

Why did the equipment stop working?

The causes were divided into:

- Easily manageable causes: blown bulbs, faulty electrical connections, blown fuses, etc.
- Preventable causes: poor maintenance, inadequate cleaning, breakages during transport, etc.
- Unknown or complex technical causes.

On average, easily manageable or preventable causes were responsible for more than a third of the equipment that had stopped working (Figure 4).

Breakage due to poor handling, for example, “being dropped” or “damage during travel to outreach,” raised questions about the care taken with equipment.

For how long did the equipment not work, and why?

On average, over 20% of all the eye units who responded to the survey reported that they had equipment which was not working for more than 12 months (Figure 5). In one extreme case, slit lamps were not working for over 15 years.

The key trend noted was that equipment not working for longer than a year was predominately a problem within government hospitals. For example, 59% of government units reported that slit lamps remained unrepaired for more than 12 months, compared to 3% in private settings and 0% in NGO settings (Figure 6).

Figure 4. Causes of equipment not working

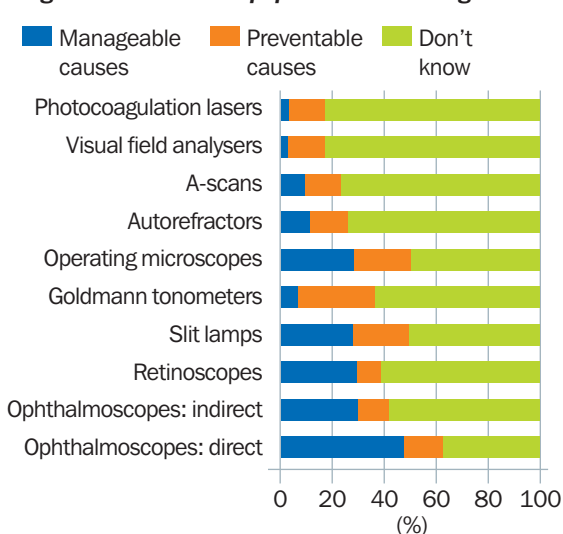

Figure 5. Percentage of eye units in which basic equipment did not work for different time periods

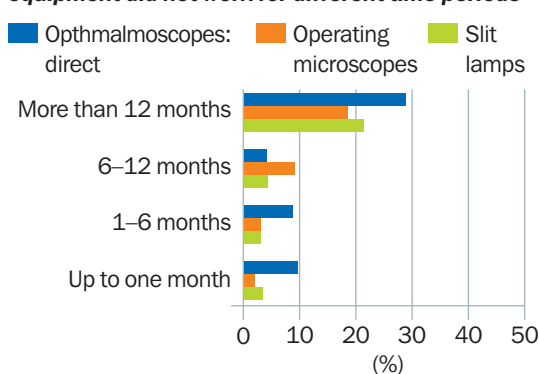
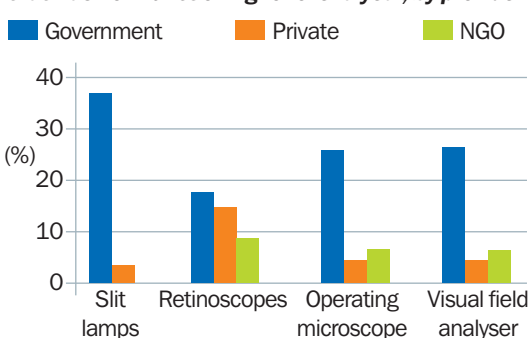

Figure 6. Percentage of eye units with equipment that was non-functioning for over a year, by provider



Why did equipment not work for long periods of time?

One of the common reasons that equipment did not work for long periods of time was that the model was too old and that spare parts were not available; this was true for slit lamps, retinoscopes, indirect and direct ophthalmoscopes, and visual field analysers in particular.

“No-one to fix it” was a common reason given in the African region.

Lack of funding, especially in government settings, was raised as a major barrier in all regions.

Figure 7. Reasons equipment did not work for a period of time

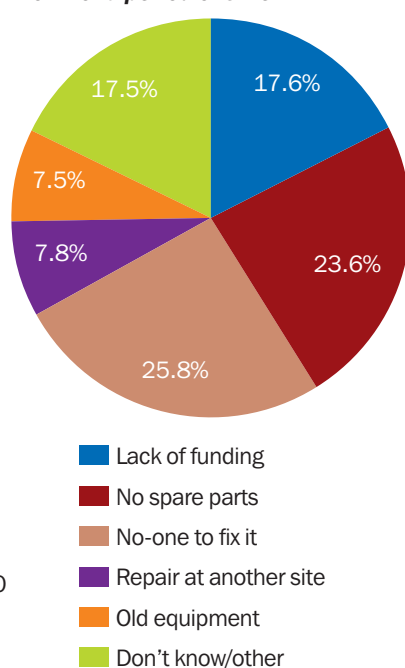

In total, 60% of the units indicated that they had no reporting system or log for faulty equipment. Furthermore, there was no designated person to take responsibility for the equipment that did not work. This could help to explain the delays in arranging for repairs.

Nursing staff in only 31% of the units had received any form of training to maintain or clean the equipment.

Specialist training for technicians was available for only 33% of the eye units overall. In total, 51% of the eye units reported having access to the services of a trained general technician. One of the respondents pointed out that access to a general technician was not sufficient: “We have two medical technicians who are looking after all the medical equipment in the hospital. We need somebody who can [teach] them ophthalmic instrument maintenance.”

Figure 8. Percentage of eye units that cancelled services due to lack of functioning equipment

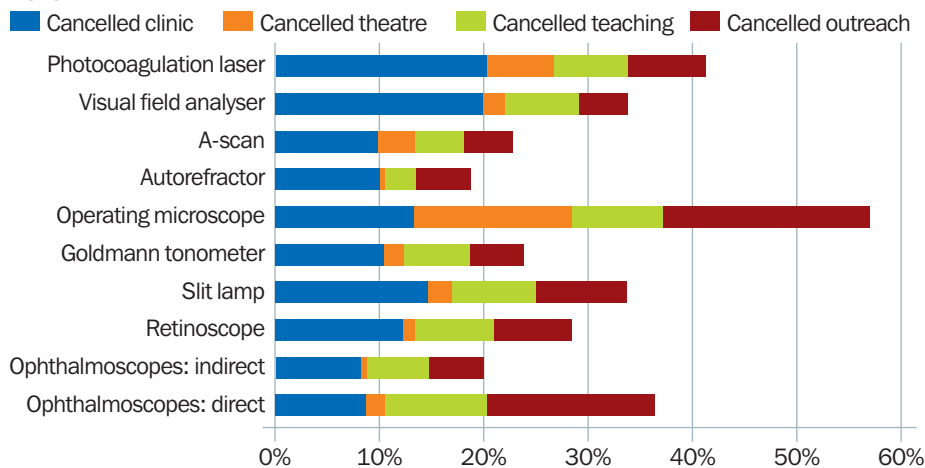

The impact of equipment that did not work

Some eye units have had to cancel or reschedule clinics and operations when their equipment broke down. Outreach programmes in almost 20% of the eye units were cancelled at some point due to lack of operating microscopes, which meant that screened patients have had to be turned away.

For both outreach services and those at the clinic, the inconvenience to patients is great, particularly in rural areas where patients often have to travel long distances. Long-term or repeated cancellations result in disappointment and loss of trust. This can damage the reputation of the eye care service and will have an impact on its ability to attract patients in future.

The impact of breakdowns was described as “increased waiting times for patients”, “delays due to sharing of equipment”, and “referral without a proper examination.” In addition, inability to conduct a proper preoperative assessment (due to non-functioning slit lamps) increases the risk of complications and poor visual outcomes.

Delays and cancellations are frustrating for eye care staff and have an impact on their motivation; this will in turn diminish their ability to deliver high-volume, high-quality services. As a result, retention of trained professionals in poorly equipped centres may become a challenge.

Problems with donated and surplus equipment

Donations reported by respondents included sophisticated diagnostic equipment which was not a priority requirement. These included equipment for fluorescein and indocyanine green (ICG) angiography, optical coherence tomography (OCT), and a Heidelberg Retina Tomograph (HRT).

Some donated equipment was not

working because it required specific accessories that were either difficult to obtain or unaffordable. One of the respondents noted as follows: “[...] three donated virectors but only one is working. From the beginning they needed different accessories that must be bought in order to use the machine.”

Some donated equipment no-one knew how to use. Respondents also did not know why some items were given to them (in some cases, the items were purchased by central government suppliers). These items included lasers for retinal photocoagulation, phacoemulsification machines, and retinoscopes. In one instance, a respondent reported being unable to use donated retinoscopes “because their training is in [a] French system.”

Some equipment was donated “without warranty or instructions for use and handling,” as reported by an African respondent.

Other equipment, such as A-scans, ultrasound appliances, OCT, and Yag lasers, had been purchased but was awaiting assembly for a long period of time (over six months). There are several possible reasons: because the equipment was not really needed, because there was no-one assigned to take responsibility for it, or because there was no-one who was able to assemble it.

Recommendations

- All clinical staff should be trained in basic maintenance of commonly used equipment for a district level eye unit.
- When new equipment is purchased, staff should be instructed in the basic care and maintenance that the equipment requires.
- Every unit must nominate an ‘equipment person’ who has a keen interest in maintaining equipment. This person should be supplied with a clear job description, which includes

maintaining an inventory list for equipment and spare parts, reporting on the functionality of equipment, and tracking repair work. This person should have undergone at least some basic training in equipment maintenance.

- More ophthalmic and biomedical technicians need to be trained in ophthalmic equipment maintenance.
- A module on the maintenance and repair of commonly used equipment found at the district eye unit should be developed and embedded into the training curriculum of all mid-level eye care workers.
- Local or regional equipment maintenance and repair training centres should be established.
- Donors of equipment should inform the potential recipient what is being donated and what support (consumables, spare parts, maintenance, water and electrical supply) will be required. Before accepting the donation, the recipient must ensure that they can fully support the equipment and that they have the budget to do so (see article on page 32).
- New items of equipment should be purchased with all spare parts and consumables for at least the first year of use (see article on page 34).
- Arrangements need to be made ahead of time for the maintenance and repair of both donated and purchased equipment.
- Newly purchased equipment should be installed by the manufacturer or supplier, where possible, and training given to staff on the basic care and maintenance that the equipment requires.

Equipment is central to service delivery and quality and is closely linked with the motivation of eye care personnel to do their job. More efficient, effective, and long-term use of equipment will be possible if eye units are able to acquire appropriate equipment which meets their needs, which they are trained to use and care for, and which they can afford to maintain.

Our thanks to everyone who responded to the survey, including the MSc Community Eye Health alumni. Special thanks to William Felch from the International Council of Ophthalmology and Marcia Zondervan of the ICEH Links Programme for allowing us to expand circulation of the survey through their contact databases.

References

- 1 Ophthalmic instruments and equipment. A handbook in care and maintenance. V. Srinivasan and RD Tulasiraj 2003 pg 4–5.
- 2 See page 36 for details on how to get a copy of the Standard List.

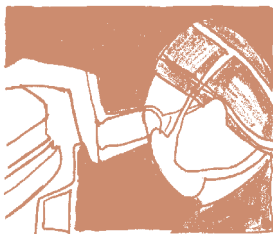

Equipment maintenance and repair



DS Walia

Director of Clinical Services: Eye Unit,
PCEA Kikuyu Hospital, PO Box
45-00902, Kikuyu, Kenya.
Email: dcseye@pceakikuyuhospital.org



Jane Huria

Instrument Repair Technician, Eye Unit,
PCEA Kikuyu Hospital.



Ismael Cordero

Senior Clinical Engineer, ORBIS
International, 520 8th Ave, 11th Floor,
New York, NY 10018, USA.

The repair and maintenance of ophthalmic equipment, including surgical instruments and diagnostic devices, can be compared to the maintenance of a motor vehicle, something many of us understand well.

If you had a car, would you drive it until the fuel runs out or until a tyre punctures, and then abandon it to buy a new car? Of course not. However, many eye care units purchase (or receive as a donation) expensive and delicate equipment which, because of poor maintenance, ends up breaking down. If there is not a system in place to report breakdowns and to plan or carry out repairs, equipment can remain unusable for long periods of time. Sometimes, this equipment ends up being dumped. (Figure 1).

Good maintenance habits and an effective repair system will minimise the amount of time equipment is unusable.

Who does what?

In our experience, approximately one-third of problems reported with ophthalmic equipment arise from problems caused by the user, one-third from easy-to-solve technical problems (such as a blown bulb or fuse, or a loose power cord), and only one-third require more serious fault-finding procedures and special knowledge of the equipment. Equipment users therefore have a significant role to play in the everyday care and maintenance of equipment.

Usually, a well-balanced mix of user, in-house, and out-sourced maintenance and repair leads to the best results – both technical and financial – in settings with limited resources. If it is not feasible for an eye care unit to have an in-house

‘The maintenance and repair of equipment should be centrally managed’



Figure 1. An operating table lies abandoned outside a hospital in a low-income country.

equipment maintenance and repair team, you may consider sharing such a service among several units. Depending on the equipment, you may have a service contract with the vendor or manufacturer, who will be responsible for more complex maintenance and repairs. These will be carried out by specialised maintenance and repair personnel, either employed by the vendor or manufacturer, or working as independent maintenance contractors.

Whatever system your eye unit has in place, the maintenance and repair of equipment should be centrally managed. The person responsible (the ‘equipment person’) will assign tasks, keep maintenance and repair records, design maintenance schedules, and arrange the necessary training of staff.

Sometimes, maintenance or repair support may be required from vendors and other external maintenance contractors. In all of these instances, it is important that a designated person at the eye care unit is monitoring the responsiveness, quality, and cost of the service provided.

Preventative maintenance

Preventative maintenance prevents breakdowns and ensures that equipment is operational and safe to use. It also guarantees the accuracy and reliability of equipment (that the autoclave sterilises properly and the keratometer readings are correct, for example) and saves money: it can reduce the running costs of equipment and is cheaper than repairs following a breakdown.

Preventative maintenance consists of a number of tasks of varying technical complexity, carried out by different groups of people.

- **Equipment users**, including clinic and operating theatre staff, can be trained to perform many of the simple care and maintenance duties that need to be done on a regular basis, such as dusting, cleaning, lubricating, protecting, and checking equipment, including safety checks.
- Other maintenance tasks can be performed by an in-house or shared **maintenance and repair team** that has been given additional training. These include tasks such as cleaning a microscope lens, replacing an electronic component, performing a

mechanical adjustment, or any other action that requires mechanical skills and/or a knowledge of electronics.

- More complex work has to be done by **specialised maintenance and repair personnel** contracted or employed by the vendor or manufacturer.

Preventative maintenance schedules

It is important to have a schedule for preventative maintenance of each item of equipment. This consists of a **timetable** stating when (and how frequently) maintenance should be done, and a **list**

of maintenance activities for each item. These schedules should provide simple guidelines for all types of equipment, covering the tasks to be undertaken in the following areas:

- Care and cleaning
- Safety checks
- Functional and performance checks
- Maintenance tasks (changing bulbs, lubricating moving parts, etc.)

The best source of this information is usually the manufacturer's user and/or service manual.

Schedules need to be developed separately for both users and

maintainers. For example, users can perform checks and basic maintenance tasks on a daily basis, whereas the maintenance team can set aside a specific day of the week or month to carry out regular maintenance tasks. More sophisticated maintenance tasks, such as those which need to be carried out by service agents, should be scheduled for a specific day or week in the year.

It is helpful to display maintenance schedules for users on or near the equipment they refer to; this can serve as a useful daily reminder of the tasks that should be performed.

Continues overleaf ➤

TOP TIPS Equipment care

Tools

Where possible, avoid using hammers, pliers, and files: these usually cause irreparable damage. Use the right tool to tighten screws and other parts.

Lubrication

- **Petroleum jelly** (Vaseline) or white grease is good for lubricating parts that have gears or sliding surfaces. It is clear and less likely than regular grease to leave stains on hands and clothing.
- **Silicone spray** is useful for sliding plastic or nylon parts. Take care not to spill any on the floor as it is very slippery and hard to remove.
- **Graphite** can be used as a dry lubricant (or as a paste) for moving or sliding parts.
- Avoid **excessive use of oil** as it is messy and collects dust.

Foot pedals

These frequently become wet when floors are being cleaned, especially in the operating theatre. Moisture seeps into the electrical components of the foot pedal which with time will stop working. Always place any foot pedal off the floor when mopping.

Wires and optical fibres

Wires and optical fibres from equipment such as laser machines, vitrectors, indirect ophthalmoscopes, etc. have very delicate interiors and/or optical components within them, and some of them may carry power or electricity and heat up with use. Staff should know how to handle and fold them properly in order to prevent damage. In situations where wires and fibres have to lie on the floor, they should not be walked on or run over with heavy items such as trolleys or other wheeled furniture and equipment.

Lenses

Protect lenses from dust by always covering optical equipment when not in use.

Humidity, or liquid spilled on instruments, can cause fungal growth (mould) on lenses. Many producers of optical equipment supply sachets of silica gel drying agents or fungicidal (anti-mould) pellets that you can place inside the dust cover. You can also use a dehumidifier to keep the air in the room dry.

Electrical connections



Matt Baretich

Pulling on the cord instead of on the plug can damage the wires.

Check that equipment is plugged in properly and that the cord is not in danger of shorting (for example, if it is exposed to water or steam) or in danger of being cut.

Handle plugs (or connectors) with care. A break in a wire inside the plug casing is hard to find and causes equipment to work intermittently. This can result from bending the wire at the same place or unplugging from the socket by pulling on the cord.

Power sources

Expensive and delicate equipment such as bench-top autoclaves, lasers, microscopes, slit lamps, and vitrectors can be severely damaged by sudden surges in electricity. Using a **voltage stabiliser** or **regulator** will protect equipment against damage and will generally also prolong the life of equipment. We recommend good quality units which monitor the mains voltage continuously. Look for units

which will stabilise the output to ensure the voltage reaching your equipment remains constant at 230V ($\pm 6\%$). If the input voltage falls below 142V or rises above 295V, the stabiliser will automatically disconnect the output. Stabilisers of poorer quality may be overwhelmed by large fluctuations, which will then damage any connected equipment.

The use of an **uninterrupted power supply** (UPS) unit is strongly recommended for equipment such as A-scans, visual field analysers, fundus cameras, lasers, and operating microscopes. This ensures continuous operation of the equipment and less inconvenience for both surgeons and patients when there are power failures. We recommend using a UPS that is also able to act as a voltage stabiliser and protect the equipment against power surges. The type of UPS and its power output requirements can easily be determined by a qualified electrician. Equipment suppliers may also be able to give these details.

Using equipment for outreach

Equipment and instruments that are transported for outreach work need to be packed and carried with special precautions so they are not damaged in transit.

Heavier equipment such as operating microscopes should be carefully dismantled and packed in damage-proof containers. Specially designed microscopes for mobile use are available with proper packing containers for safe transport.

Sufficient stock of light bulbs and fuses should be carried together with a set of screw drivers and other basic tools. Staff travelling with outreach programmes should know how to pack, set up, and dismantle the equipment.

With thanks to Ingrid Mason, Neil Murray, Kola Ogundimu, Sam Powdrill, Tony Walla, and Ismael Cordero.

Repair

Repair means responding to the breakdown of equipment and undertaking work to correct the problem in order to return the equipment to a working condition.

Before equipment can be repaired, you need to be aware that there is a problem! Therefore, there should be a clearly understood **system for reporting faults and breakdowns** and equipment users should be encouraged to report faults and breakdowns as soon as possible. If there is no back-up equipment, a breakdown will mean that the service the equipment was providing will come to a halt.

Simple repairs can be done by the in-house or external **maintenance and repair team**. If the equipment is repaired where it is used, it is important that the

team is trained to work safely and that they don't create hazards for patients or staff.

More complex repairs will be carried out by **specialised maintenance personnel**; they might come to the eye care unit or you may have to send the equipment to them for repairs.

In all these situations, it is important to keep equipment users informed of how long their equipment will be unavailable.

Some items of equipment will be found to be damaged beyond repair. For others, spare parts may no longer be available as the equipment has become outdated. These will have

reached the end of their lives and must be taken out of service (decommissioned or retired) and be replaced if the service they provide is to continue. Equipment that is being decommissioned should be disposed of safely and according to proper disposal procedures. Remember to update your records accordingly.

'Plan for maintenance when you purchase the equipment'

Record-keeping

In order for an eye care unit to manage its equipment effectively, it needs good

maintenance and repair records. It is very difficult to manage the unknown!

A **central maintenance and repair record** will help you to keep track of the maintenance and repair work done. Ideally, this system should correspond to the eye unit's equipment inventory (mentioned on page 34); this means that you will have maintenance and repair records for each of the items listed in the inventory.

Record-keeping for maintenance

The preventative maintenance schedule for users can be accompanied by a weekly or monthly 'tick sheet' near the item of equipment, with a space for each day so that users can date and sign it, thereby showing that they have carried out the required tasks. This may include a space for users to indicate what spare parts, such as bulbs, were used. On a regular basis, the list of spare parts used should be noted in the central maintenance and repair record so that more spare parts can be ordered.

The central maintenance and repair record can be used to keep track of all other maintenance, including maintenance done by the in-house team, by vendors, or by service agents. The information captured should include the date, the equipment reference number, what was done, who did the work, and when next maintenance is due.

Figure 2. One way of keeping track of regular maintenance tasks is to affix a tag to serviced or maintained equipment. This information should be reflected in the central maintenance record.

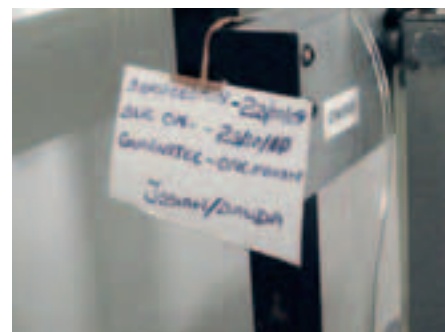

Ismael Cordero/ORBIS

What YOU can do to look after your equipment

Care and maintenance of equipment is everyone's responsibility; unusable equipment affects the quality of care we can offer our patients and makes our work more stressful.

Whatever your role in the eye care team, there is a lot you can do to look after and prolong the life of the equipment you use.

1 Learn as much as you can about the equipment you use

- Find out where the manual is kept – and make time to read it. If possible, keep the manuals close to the equipment.
- Make sure you get every issue of the *Community Eye Health Journal* over the next three to four years – we are publishing a new series on equipment care, maintenance, and repair which will have practical tips and guidance on the most used items (see the first instalment on page 37).
- Look at 'Useful resources' (page 36) for additional sources of information.

2 Check equipment before use (or at least once a week)

- Inspect equipment for any sign of damage or parts that may need repair or replacement, and lubricate as necessary (according to instructions).
- Check that equipment is plugged into the voltage stabiliser or uninterrupted power supply, where these are required.

3 Tell someone if there is a problem

- As a user, it is your responsibility to report any problems. You will most likely be the first person to know that something is not working as it should.

- Don't assume that someone else will report a fault – what if everyone thinks that someone else will report it?
- It may sound obvious, but a repair can't be attended to if nobody knows there is a problem. The longer you take to report it, the longer before the repair will take place.
- Don't wait for equipment to break down before reporting a fault. Even a small change in how the equipment moves or how it responds could indicate that something has gone wrong or that a part needs to be replaced soon. If left unchecked, a more serious fault may occur, which will be more expensive and time-consuming to repair.

4 Clean equipment after use (or at least once a day) and lubricate when necessary

- Dust and then clean equipment, including optical components, with the appropriate cleaning agents and solutions. Lubricate moving equipment as often as indicated. Always follow the instructions.

5 Protect equipment when not in use

- Store equipment in a dry, clean environment where it is not in danger of falling and breaking.
- Place plastic dust covers on larger equipment like slit lamps in order to prevent damage to the optics and other delicate components. If cloth is used, ensure it is heavy and non-porous, or else dust will get through.
- When transporting equipment, pack items securely and handle with care.

Record-keeping for repair

Table 1 shows what information about repairs should be recorded in the central maintenance and repair record, and what useful information this can provide.

In addition to the practical benefits of a central maintenance and repair system, it also provides eye care unit administrators and the equipment maintenance team with valuable information and proof that they can use to ask for more resources.

Budgeting for maintenance and repair

When we purchase a motor vehicle, we understand that we will have recurring costs for maintenance, theft and accident insurance, cleaning, parking, etc. The same is true for ophthalmic equipment since it costs money to operate and to maintain during its life cycle.

On average, the original purchase cost only makes up about twenty per cent of the entire life cycle cost of the equipment. As a general rule, you should budget anywhere from 3% to 6% of the equipment purchase cost per year for each device to cover consumables, parts, maintenance, and user training.

Plan for maintenance **when you purchase**

Table 1. Record-keeping for repair

What should be recorded	This provides information about ...
The details of repair work done on each machine (including cause/suspected cause, and who carried out the repair)	<ul style="list-style-type: none">• The history of each machine• Common problems
The spare parts and materials used	<ul style="list-style-type: none">• The parts most frequently used• What needs to be re-ordered
The date equipment has broken down, and the date it is repaired.	<ul style="list-style-type: none">• What still needs to be repaired (which allows you to prioritise the next week's tasks)• The duration equipment is not in use (down-time)
The causes of any delays	<ul style="list-style-type: none">• What the most common causes of delays are (skill, labour, spare parts, transport, bureaucratic delays, money) and what additional resources may be needed to complete work on time

the equipment and ensure that you buy the necessary accessories (including voltage stabilisers/surge protectors and uninterrupted power supply units) as well as enough spare parts (bulbs, fuses, and so on) to last for at least a year.

In conclusion, adopting practical and workable systems to manage eye care equipment, as suggested in this article,

will help you to get the most use out of the equipment you have. With equipment, prevention is usually better than cure! It is also good practice to keep learning and to stay open to new ideas. Communicate with colleagues in other eye units, whether locally or through the internet, about the challenges you face and share with them the solutions you have found.

Copyright © 2010 DS Walia, Jane Huria, and Ismael Cordero. This is an open access article distributed under the Creative Commons Attribution License, which permits unrestricted use, distribution, and reproduction in any medium for non-profit purposes, provided the original work is properly cited.



EXCHANGE

Multiple mobile operating tables for eye surgery



Jonathan Pons

Ophthalmologist and Programme Director, Good Shepherd Hospital Eye Care Project, PO Box 218, Siteki, Swaziland.

Email: jono@goodshepherdhosp.org

High-volume eye surgery requires that patients be moved quickly in and out of the operating room (OR). Static operating tables in the OR make this difficult. Better patient flow can be achieved when using mobile tables, which can be expensive. We have developed an economical, wheeled operating table that can be constructed in a local engineering workshop.

Because this mobile operating table can transport the patient between the different areas before, during, and after an operation, the patient can stay on the table throughout and does not have to transfer beds. Four tables are in use at any one time: one for a patient being prepared for surgery, one for a patient being given local anaesthetic, one for a patient being operated on, and one for a patient being wheeled out of the OR and returned to the ward.



One patient recovers after the operation while another is given local anaesthetic. SWAZILAND

Our finding is that multiple mobile operating tables minimise interruptions in the flow of work; surgeons can concentrate on surgery and may stay scrubbed for the entire day. The tables improve

patient comfort through better head support and are also more comfortable for surgeons as they leave more room for surgeons' legs. Another advantage is that fewer staff are needed to manage the flow of patients. The results are dramatically improved time and cost savings: one surgeon can comfortably perform up to forty eye operations in a day.

The tables are designed to be manufactured in a local engineering workshop and the simplified design incorporates the following:

- A tubular steel welded frame
- A bed made of a shaped stainless steel sheet
- Adjustable bed height (using a simple hand-operated thread)
- A head end with non-castoring wheels for stability during surgery
- A foot end with lockable castoring wheels
- Bumpers on all wheel mountings, which prevent contact damage with door frames.

Each table costs approximately UK£300 to produce and drawings are available from the author.

Copyright © 2010 Jonathan Pons. This is an open access article distributed under the Creative Commons Attribution License, which permits unrestricted use, distribution, and reproduction in any medium for non-profit purposes, provided the original work is properly cited.



Training for equipment maintenance and repair



Sam Powdrill

Assistant Professor, University of Kentucky College of Health Sciences, Division of Physician Assistant Studies, 900 S Limestone Street, Lexington, KY 40536, USA.



Ismael Cordero

Senior Clinical Engineer, ORBIS International, 520 8th Ave, 11th Floor, New York, NY 10018, USA.



V Srinivasan

Aravind Eye Care System, Madurai, India. Email: v.srinivasan@aravind.org

In order to ensure that equipment functions well, both equipment users and the equipment maintenance and repair team must be trained. Users must be trained in basic care and maintenance of equipment, and the equipment team must be trained to undertake repairs and more complex maintenance tasks.

Training equipment users

The primary responsibility for the care and maintenance of equipment rests with the user. Users should understand how their equipment works, what its limitations are, and what it can and cannot do. All of these are usually well described in the user manual that is supplied by the equipment manufacturer or supplier. It is important that users read and understand the user manual and keep it in a safe place.

In situations where surgeons or clinicians work under extreme time pressure, they may not be able to pay sufficient attention to the care and maintenance of the equipment they use. In this case, nursing staff and patient attendants can be trained in basic preventative maintenance and care. However, surgeons and clinicians must still be trained to use equipment properly and safely; they are also responsible for reporting faults and should be included in discussions about maintenance and repair.

Users should be trained to do the following **preventative maintenance** tasks on a regular basis (check the manufacturer's guide or user manual for details):

- Clean outer as well as inner surfaces and lubricated parts.
- Check for damage, loose or missing screws, and corrosion.

- Change filters and renewable parts.
- Lubricate movable parts.

All users, including clinicians, are responsible for the **safety** of their equipment. Users should be trained and encouraged to do the following:

- Carefully wipe the surfaces of the instrument regularly with a disinfectant, particularly those parts that come into contact with the patient, such as the chin rests on the slit lamp and keratometer.
- Check for sharp metal or broken lenses in the instrument that could injure the patient or user.
- Keep equipment, tubing, tools, and electrical cords out of the path of patients who may be blind and could trip over them.

Top tips for training equipment users

- Demonstrate what to do.
- Allow the student to actually do the work and practice under supervision.
- Maintain a friendly environment, rather than a highly competitive environment, in which to learn.
- Be patient with your students, but expect effort and excellence.
- Always have a back-up plan in case equipment breaks or a part is not available.

The person responsible for equipment in the eye unit (the 'equipment person') should periodically remind staff about the proper care and use of equipment, using the user manual as a guide to discussion.

Training the equipment maintenance and repair team

Since new makes and models of equipment are constantly becoming available, the equipment maintenance and repair team needs to update its skills continually. Training should cover:

- Preventative maintenance and repair for maintainers
- Teaching preventative maintenance to users
- Maintenance management
- Management of stocks and stores
- Procurement procedures
- Financial planning and accounting
- How to work in a health facility environment.

The equipment team also needs other skills common to equipment users, such as:

- Basic do's and don'ts when handling equipment
- How to operate equipment
- Basic anatomy, physiology, and medical terminology
- Cleaning of equipment
- Safety procedures.

Training is not an activity that only happens once. Training is required at various times throughout an employee's career:

- Induction training: when staff are newly placed in post, move to a new department or facility, or to a new location with different responsibilities
- Training when new equipment first arrives
- Refresher training: regular training to update and renew skills throughout the working life of staff.

After training, the team can be expected to do the following:

- Communicate effectively with clinical personnel on medical equipment and safety issues.
- Train users to operate and care for equipment properly.
- Perform repairs in a cost-effective and timely fashion.

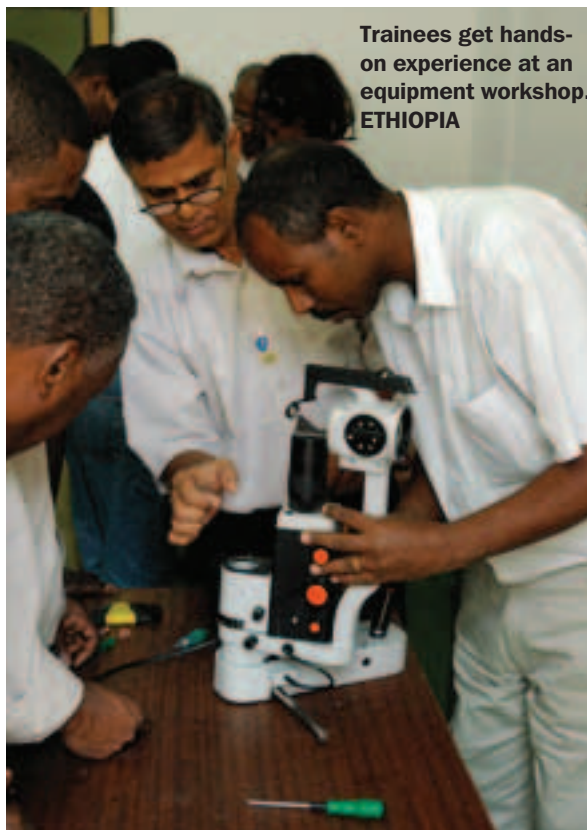

Ismael Cordero/ORBIS

- Help to establish a safe environment for patients and staff.
- Take part in decision making about medical equipment management, planning, and procurement.

TIP: If an item of equipment is used far away from the location of the manufacturer or supplier and service personnel are not available, an effort must be made to obtain the service manual. This manual contains more detailed information than the user manual and is usually reserved for the use of contracted service personnel. Reading and understanding the service manual will give in-house maintainers the information they need. Keeping it safe is essential.

Top training tips

- Send staff to factories that manufacture equipment.
- Invite engineers from manufacturers to visit your facility to conduct training on their equipment.
- Send staff to other locations which have already developed the skills required.
- Link the provision of training by the vendor to the procurement process.
- Run in-house (on-the-job) training sessions.
- Make use of regular clinical/professional meetings.
- Make use of academic courses at various levels.
- Approach local colleges to develop, run, and accredit new modules specifically designed for your equipment needs.
- Provide opportunities for practical, on-the-job experience.
- Provide opportunities for studying and teaching.
- Let maintenance staff attend peer group meetings or conferences.
- Provide various training materials for staff to refer to.
- Provide work placements (internships) for students in your workshop.

Managing, motivating and retaining skilled staff

- Create multidisciplinary teams so that staff are not overstretched.
- Use suitable reporting and feedback methods so that staff know what is going on.
- Evaluate staff performance so that career development goals can be set.
- Help staff to develop their skills.
- Put in place suitable employment conditions such as a salary, holiday and sickness leave, and overtime entitlements.
- Ensure suitable working conditions, such as supportive supervision and suitable tools.

Establishing and running an equipment workshop

In general, hospitals with fewer than a hundred beds are more likely to save money and maintain quality by outsourcing equipment maintenance as opposed to having an in-house maintenance department.

Most small health organisations simply cannot provide the needed resources, such as salaries for qualified technicians, to operate a good quality in-house workshop. However, larger hospitals may find it helpful to have their own workshop. The main benefits are:

- Better control over the maintenance budget
- Faster response speed
- Better understanding of user needs and organisational priorities.

You can find out whether an in-house equipment workshop will save costs: compare the money spent on maintenance performed by outside vendors to the anticipated initial investment and recurring expenses needed to establish and operate an in-house workshop. It is important to note that, even with an in-house workshop, there will always be a need for outsourced maintenance services, for example when the equipment is too complex for the in-house technicians or when repairs require special tools, test equipment, and service manuals. Most medium-sized health organisations will therefore have a mix of in-house and outsourced maintenance services.

In smaller hospitals, the role of medical equipment maintenance may be incorporated into the facilities maintenance department. Smaller hospitals that are part of a larger hospital system may also receive their medical equipment maintenance services from the medical equipment maintenance department of the central tertiary hospital of the system.

What do you need?

The workshop should be staffed by **maintenance personnel** of varying skill levels (artisans, technicians, and engineers) according to the amount and complexity of equipment in the health unit. As a rule of thumb, for every 100 beds at a district hospital there should be two medical equipment maintenance technicians.

Ismael Cordero/ORBIS



An equipment maintenance workshop in a district-level hospital. ETHIOPIA

You will also need a **budget** to pay the setup and ongoing costs. The **setup costs** include the cost of tools, equipment, parts, materials, and the physical space for the workshop, as well as the costs of recruiting and training staff. The

ongoing costs are salaries, consumables, spare parts, replacement tools, and ongoing training.

It is important to have an **equipment workshop management plan** that includes department policies, procedures, standards, and guidelines.

The **workspace** must be big enough to accommodate the equipment technicians and their physical resources. Maintenance work on eye equipment, in particular, requires a separate workspace that can be kept clean to avoid damage to lenses, etc. You will also need:

- Workbenches, stools, shelves and other furniture
- An office area with desks, filing cabinets, a notice board, telephone, etc.
- Work lights
- Repair tools
- Test and calibration equipment
- Safe storage for user and service manuals
- Sufficient number of electrical outlets
- Ventilation
- Running water and a sink
- Secure storerooms for spare parts and materials
- Secure outside storage areas for gas bottles, old or unrepairable equipment awaiting safe disposal, etc.
- Where possible, a computer for keeping your equipment inventory and repair records and accessing the internet to obtain technical information, source vendors and parts, and participate in equipment maintenance discussion groups to solve problems.

You should have enough **spare parts** in stock, which may need to be pre-ordered from the manufacturer or distributor. Useful spare parts to have include specialised light bulbs, gaskets, air filters, and other equipment-specific parts that wear out frequently.

Most of the other maintenance materials you need can be found in local markets, such as oil, grease, electric cables, washers, screws, fuses, generic light bulbs, cleaning agents, disinfectant solutions, brushes, and cloths.



Donations: how to ensure you really benefit



Ismael Cordero
Senior Clinical Engineer, ORBIS
International, 520 8th Ave,
11th Floor, New York, NY 10018, USA.



Neil Murray
Medical Advisor, CBM West Africa.
Email: n.murray.cbm@gmail.com



Henry E Nkumbe
Medical Advisor, CBM Madagascar,
SALFA Eye Project Antananarivo, PO Box
3825, Antananarivo 105, Madagascar.

Appropriate donated equipment or consumables can help to achieve the goals of VISION 2020. However, according to the World Health Organization (WHO) Guidelines on Healthcare Equipment Donation (2000), an estimated 70% or more of donated medical equipment is not being used.

Why do things sometimes go wrong?

Some of the causes are:

- Inadequate communication between the donor of the equipment and the receiving eye unit, so that the eye unit ends up with an item which is not appropriate, is not robust, cannot be maintained, does not include spare parts or a manual, and which no-one knows how to use.
- Failure to identify all the costs involved, such as training, shipping and clearing, and operation and maintenance.

Before you accept a donation

Think about the following:

- Is this something you really need, and is it the best use of scarce resources? For example, has the donation of sophisticated devices (phaco machines, lasers, or ultrasound machines) been balanced against the need for basic public health equipment such as ophthalmoscopes?
- Is it the right tool for the job? Is it an appropriate make and model? Refer to the *IAPB Standard List for a VISION 2020 Eye Care Service Unit 2010* (Standard List). See page 36.
- Does your organisation have the necessary resources and skills to make good use of it?
- Do you have the budget to use and maintain the equipment in the long term? You will have to budget 3–6% of

the purchase price of the donated equipment per year for consumables, parts, maintenance, and user training. This may or may not form part of the donation.

- Is the potential donor a credible individual or institution? Talk to others who have received donations from them. Give preference to items from companies with an established track record for after-sales service in the country or sub-region; most of these companies are in the Standard List.

Talking to a potential donor

Explain your needs, and how the requested equipment or consumables will meet these needs. Describe:

- Why the resources presently available are not satisfactory
- What specific interventions the requested equipment or consumables will be used for
- Which and how many procedures will be performed using them
- How they will help you meet the expected demand.

If your donor is overseas or is likely to import the equipment or consumables, first ensure these cannot be purchased locally at competitive prices. Encouraging donors to buy locally will help develop local markets and will make it easier to get direct support from the vendors without needing to involve the donor.

Show that you are a credible organisation. You could do this by providing a list of references (your ministry of health, non-governmental organisations, charities, or religious institutions) which the donor can contact.

TIP: Ask for photographs of the equipment you are requesting, where possible. This will reduce confusion and possible waste, as equipment and instruments may have different names depending on where a person was trained, particularly in non-English speaking countries. Many projects have requested instruments and equipment that were never used because they asked for the wrong item.

Questions to ask the donor

As mentioned in our article on purchasing (page 34) getting a new item of equipment is not a simple matter. Equipment may require some or all of the following:

- Installation and user training
- Regular preventative maintenance
- Breakdown support
- Accessories and spare parts
- Supporting materials
- Electricity and water supply.

The questions below should help you cover all the most important aspects of the donation with your prospective donor.

1. Installation

Who will be able to install the equipment? If your eye unit does not have the skills and resources required, is the donor willing to arrange and pay for installation? Who will train the people who will use the equipment?

2. Regular preventative maintenance

How will the equipment be maintained on a regular basis? Will this mean training the people who will be responsible? If so, how can this be achieved?

Ideally, training in maintenance should be given at the time of installation, although it is also possible to arrange training with a similar piece of equipment in a neighbouring eye unit before the donated equipment arrives.

Especially with very expensive, unfamiliar, or sophisticated equipment, some users may feel

reassured if an experienced user were available to demonstrate proper assembly, use, and routine maintenance. Short of this, complete documentation in the local language (including circuit diagrams for local maintenance technicians and engineers) should be made available.

3. Breakdown support

Despite your best efforts to keep equipment in good working order, breakdowns may occur from time to time. Is there an agent in the country and within easy reach to undertake the repair or

‘Explain your needs, and how the requested equipment or consumables will meet these needs’



Neil Murray

shipped in accordance with international shipping regulations, with appropriate packing for the donation and mode of transport. Documents must list everything in the shipment and clearly indicate that it is a donation. You will need to check the customs regulations in your country and inform the donor in advance, before shipping, to reduce the risk of high clearance charges and delays, which may result in extra charges by the shipping company (demurrage).

After receiving the donation

Make sure you read and understand the user manual and then familiarise yourself with the equipment before attempting to assemble or operate it.

Ensure that each item of equipment has a maintenance plan that is respected and followed, and that there is a budget allocated for maintenance each year.

Keep the donors informed about both the successes and challenges with the donated equipment – this will help you to build a positive, and hopefully long-term, relationship.

In conclusion, maintaining open communication with your donor and following these guidelines should ensure that your donation goes smoothly. With time, your eye unit will be able to demonstrate that the donations have resulted in improved services that bring satisfaction to patients, staff, and the donor.

If you are a donor

Develop a relationship with the eye unit.

What do they need? Find out what equipment is best suited to their work and environment. This depends not just on the durability and functionality of the equipment, but also on the eye unit itself – does the unit have staff with the knowledge and skills needed to use the equipment? Can the unit afford the operation and maintenance of the equipment?

Balance need and quality.

Although it is not appropriate to donate out-of-date equipment, an eye unit in a low- or middle-income country may be able to use equipment that is no longer considered suitable in a high-income setting. However, it is your responsibility to ensure that the equipment meets the eye unit's needs and that maintenance and repair support, as well as spare parts, will be available for each donated item for the next 5–10 years.

This donated phaco machine has ended up in the back cupboard of an operating theatre. It was never used because of a lack of parts and problems with the power supply. SIERRA LEONE

perform preventive maintenance and calibration services? If yours is to be the only piece of equipment of this make and model in the country, or if breakdown support is non-existent or very expensive, you should discuss these issues with the donor. Would it be best to refuse the donation and ask for an item of a different make or model?

Especially with sophisticated and expensive equipment, preference should be given to companies with established track records for after sales service in the country or sub-region.

4. Accessories and spare parts

What essential accessories and consumables will be required, such as cables, reagents, filters, electrodes, and recording paper? Are they being donated? If not, can they be obtained locally and does your eye unit have the budget to buy them?

Does the donation include the necessary spare parts? If not, are spare parts easily available locally, and can you afford the monthly or yearly costs?

You can request that donors include commonly required spares (such as replacement bulbs, fuses, etc.) in the donation, as well as any other items that would take longer than six months to be delivered.

5. Supporting materials

Above all, you need to check that the donated item comes complete with all appropriate installation instructions and operating manuals in a language you can understand. Ideally, there should be expertise locally to support the installation and maintenance, but it is worth asking the donor whether there is also a remote troubleshooting facility such as an internet or telephonic technical help desk.

6. Electricity and water supply

Has the equipment been fitted with all the devices it needs to work in your location? For example, electrical equipment needs the correct electrical plugs, voltage surge protectors, and other devices necessary to ensure regular, uninterrupted power supply (see 'top tips' on page 27).

If the item of equipment requires running water, will this be available? If not, is the equipment really suited to your circumstances?

Shipping and clearing donated equipment

You need to be sure that the donated equipment or consumables are shipped with a recent biomedical certification and a minimum one-year guarantee.

The donation should be packed and



Purchasing equipment for an eye unit



Catherine Cross

Formerly Manager, International Programmes, Sightsavers, Grosvenor Hall, Bolnore Road, Haywards Heath, West Sussex, RH16 4BX, United Kingdom.



Philip Hoare

Programme Procurement Manager, Sightsavers, Grosvenor Hall, Bolnore Road, Haywards Heath, West Sussex, RH16 4BX, United Kingdom.

If VISION 2020 is to meet its objective of eliminating avoidable blindness in ten years' time, eye units have to ensure that they have the equipment they need so they can work quickly and effectively. In this article, we aim to show you how to get the best results when purchasing (procuring) equipment.

Who is responsible?

The manager of the eye care unit is ultimately responsible for ensuring that equipment and supplies are adequate.

However, the manager may delegate a member of the team to act as the 'equipment person'. This person will have some responsibilities for ordering and will also be responsible for keeping the **equipment inventory** up to date. The inventory should contain information about all items of equipment in the eye unit: when these were bought, from whom, at what cost, and where the items are now situated in the hospital or clinic. When new equipment arrives, this should also be recorded in the inventory. The equipment inventory can be stored on computer or in a paper filing system.

The equipment person will also be responsible for ensuring that all equipment has sufficient consumables (such as reagents, filters, recording paper), spare parts (including light bulbs) and accessories (cables, electrodes, and so on) and will order replacements when stocks run low.

The equipment inventory is a good place to note how satisfied the eye unit is with the services offered by different suppliers. When it is time to order again, this information will help the equipment person to determine whether to continue with the same supplier or consider other suppliers.

Finding out what you need

The *IAPB Standard List for a VISION 2020 Eye Care Service Unit* (Standard List) is a useful guide to the equipment you are likely to need in your eye unit. The Standard List is updated every two

years by the IAPB Technology Programme Committee and also contains the names and contact details of suppliers (see page 36 for details on how to get your own copy).

With equipment, you have to be sure that what you buy will last and will suit your needs and circumstances. In addition to consulting the Standard List, we would recommend that you also obtain catalogues or visit suppliers' websites to see what is available and whether it meets your needs.

It is helpful to ask yourself the following questions about the equipment you want to buy:

- Is the item durable and can it handle heavy use?
- Is the model already in use locally and is there local expertise to repair and maintain it?
- If other local eye units are using the same or similar equipment, have they had good results, or encountered problems with the functioning or maintenance of the equipment?
- What is the cost of the item?
- What is the cost of accessories, consumables, and spare parts, and are they available in our country?
- What are the associated requirements (electrical consumption, wiring, water supply, environment, room temperature) and can we provide these? What electric voltage does the item require and is it compatible with what we have?
- If the local electricity supply is erratic,

will back-up items such as electrical stabilisers and voltage regulators also be necessary? What are the costs?

- Is training needed in the use and care of the equipment? Who can reliably conduct the training? What is the likely cost?
- Will it be necessary for the supplier to come and install the equipment and/or maintain it? Will special training in use and maintenance be needed?

NOTE: The article about donated equipment on page 32 contains some additional questions you can discuss with the supplier before acquiring new equipment. Most of these are also valid for purchased equipment.

Budgeting for an equipment purchase

Prices quoted in a catalogue or on the internet may not include value added (or sales) tax. As this varies from country to country, you may have to ask the supplier what the full cost is.

If the equipment is to be imported, the cost of packing, insurance, and clearing must be included in your budget.

As mentioned above, you also need to budget for accessories, spare parts, consumables, maintenance, user training, and electrical stabilisers, if needed. As a guide, budget 3–6% of the purchase price for every year of use. It is recommended that you order enough consumables and spare parts for at least one year when purchasing the equipment.



Philip Hoare

When buying expensive equipment such as an operating microscope, ensure that you have also budgeted for accessories, spare parts, consumables, user training, and electrical stabilisers such as voltage regulators (if needed). BANGLADESH



Henry Nkumbe

The 'Operating Room' section of the Standard List helps by placing these, with references, under the main item. Ask the supplier what spare parts may be needed in the first year, such as light bulbs, fuses, spare paper for an A-scan, and fungicidal (anti-mould) tablets; these should be ordered at the same time.

Placing the order and paying for it

Most overseas suppliers will require payment in advance or with order. The majority of the suppliers in the Standard List are tried and tested, but be cautious when dealing with unknown suppliers. You can use an inspection company such as SGS¹ or Cotecna² to verify such transactions and ensure your equipment is shipped as contracted.

It is vital to give the correct shipping details (in particular, your correct address) to the suppliers. This information will be used to ship your equipment and will be applied to all shipping documentation. If the details are incorrect it could delay the shipment and/or clearance through customs, which may result in an expensive demurrage charge (a charge applied when shipped goods are not collected on time).

The local authorities may allow you to import duty free. In such cases, a gift certificate or certificate of donation might have to accompany the shipment. At this stage, it is worth checking with the local authorities whether any other documentation is required to import your equipment, such as an inspection certificate or certificate of origin.

Receiving the order

Prompt clearance at the port or airport is important. This will reduce extra charges (demurrage) and minimise the chances of loss or damage. The member of your

team responsible for clearance will need to be familiar with the clearance procedures, including any customs and duty waiver. When placing the order with an overseas supplier, insist as part of the contract that they give you the full shipping details before shipping the

equipment. This will allow you to make the necessary plans to clear the goods well in advance of the date of shipment.

The equipment person should check the goods received against the order immediately on arrival. Are the correct items received, in the right quantity? Is

Continues overleaf ►

Members of the eye care team check the paperwork of newly arrived eye care equipment and consumables. They will also check the integrity of the boxes to ensure they haven't been tampered with en route. MADAGASCAR

Finding a supplier

Once you know what you need, look for the best supplier (if you are satisfied with your existing suppliers, you can skip this step). The Standard List is a good place to start – it contains the names and contact details of suppliers for all of the equipment and consumables it lists.

Once you have identified suppliers who can provide what you need, request up-to-date catalogues or price lists as well as more information about their products. You can ask for quotations, or invite the supplier to tender or submit a proposal.

When planning to buy expensive items, in particular, you may want to evaluate the supplier before making a decision. Ask the supplier whether they can put you in touch with some of their other customers. Suppliers who are confident in their products and services will normally be happy to do so.

You may ask to examine samples of the product being considered, or ask for a trial period with an item of equipment. At least request to see a photograph of the equipment – this will help ensure that there hasn't been a misunderstanding about what exactly you want to buy!

Depending on the product, ask whether installation, warranty, and maintenance (or a short maintenance workshop for local staff) are included in the price.

This is also a good time to negotiate access to the **service manual** (see tip on page 31), particularly if your eye unit is in a remote location and specialised

maintenance and repair personnel are not available.

Before making a final decision, ask the supplier the following:

- Do they supply the consumables and spare parts as well, or will you need to go elsewhere?
- Will they help to set up the equipment once it arrives?
- What services do they offer if the equipment breaks down, and will they send a replacement while yours is being repaired?
- Will they train local staff in maintenance and replacement of spare parts?

Preparing an order

The more details that are included on the order, the greater the likelihood of a speedy response from the supplier and of receiving exactly what was requested. Include:

- Catalogue number
- Make and model
- Detailed description of item
- Quantity
- Unit cost
- Total cost

The catalogue or supplier's website should be used to ensure that the description and specifications are correct.

NOTE: Remember to order sufficient spare parts for the first year, such as spare microscope or operating light bulbs.

'When planning to buy expensive items, you may want to evaluate the supplier before making a decision'

the quality good and is the equipment functioning as required? Delays in checking incoming goods may result in the guarantee running out before faults are discovered.

The equipment person should enter items received into the equipment inventory with details of date of purchase, model, serial number, and cost. All associated documents (including manuals, service contracts, and warranties) should be filed in a safe place.

Setting up and testing equipment

Ideally, this should be done by the supplier's agent or a medical equipment engineer, but members of the eye care



Philip Hoare

Take care when transporting new equipment. NIGERIA

team should participate in order to learn how the equipment works and how to care for it. Where there is no medical equipment engineer or supplier's agent available, it is important that the item is carefully unpacked and the manual

thoroughly studied before assembly.

Testing the equipment needs to be done thoroughly, particularly in the case of electrical items. The connections and voltage must be checked and voltage stabilisers and regulators installed in areas where electrical supply is unreliable.

In conclusion, if procurement is approached in a planned, systematic way, as described in this article, you will have the best possible chance to acquire good quality equipment that will meet your needs well into the future.

References

- 1 SGS: write to SGS SA, 1 Place des Alpes, PO Box 2152, 1211 Geneva 1, Switzerland. Phone: +41 22 739 91 11, www.sgs.com
- 2 Cotecna: write to Cotecna inspection SA, 58, Rue de la Terrassière, PO Box 6155, 1211 Geneva 6, Switzerland. Tel: +41 22 849 6900, www.cotecna.com

Copyright © 2010 Catherine Cross and Philip Hoare. This is an open access article distributed under the Creative Commons Attribution License, which permits unrestricted use, distribution, and reproduction in any medium for non-profit purposes, provided the original work is properly cited.

Useful resources: equipment for eye care

Publications



IAPB Standard List for a VISION 2020 Eye Care Service Unit 2010.

Lists the equipment, instruments, and supplies required by primary and secondary level (district) eye care units, along with suppliers and their addresses. Download from the VISION 2020 website www.vision2020.org/main.cfm?type=CLINGUIDE (2.3 MB) or order a copy from TALC (send your name, occupation, and address).

Stevens S and Naughton A (eds). Technology for VISION 2020.

Contains selected and updated articles on technology for ophthalmic practice from the Community Eye Health Journal. Available for free download from www.cehjournal.org/files/b0501.html (1.9 MB, or can be downloaded in smaller sections). Order paper copies from TALC (free to low- and middle-income countries, otherwise £5).



Srinivasan V and Thulasiraj RD. Ophthalmic instruments and equipment: a handbook on care and maintenance. 2003.

Available from Aravind (UK £1,40 / Indian Rs100) Or download from http://laico.org/v2020resource/files/instruments_book.pdf (780 kB).

Video/DVD

Ophthalmic instruments and equipment: care and maintenance

By V Srinivasan and RD Thulasiraj. A step-by-step guide to the care and maintenance of ophthalmic instruments

and equipment.

- Video (PAL format only): order from TALC (UK £7)
- DVD: order from Aravind (UK £7/Indian Rs500). Has English, Spanish, and French language options.

Past Community Eye Health Journal articles

All articles available online at

www.cehjournal.org

Vidhya SS, Srinivasan V. Technology for eye care: training in the care of equipment and instruments. *Comm Eye Health J* 2002; Issue 43, pages 43–44.

Srinivasan V. Equipment repaired is equipment gained. *Comm Eye Health J* 2009, Issue 70, s02 (online supplement, page 2). www.cehjournal.org/0953-6833/22/jceh_22_70_s02.html

RD Thulasiraj and V Srinivasan. Care of instruments and equipment: a success story. *Comm Eye Health J* 2007; Issue 61, page 16.

Equipment courses

ORBIS International conducts two-week workshops on ophthalmic equipment maintenance and health care technology management worldwide. For more information, contact ismael.cordero@orbis.org or write to him at ORBIS International, 520 8th Ave, 11th Floor, New York, NY 10018, USA.

Lions Aravind Institute of Community Ophthalmology (LAICO) in Madurai runs six-week training courses for technicians that are repeated four times a year (US \$325). LAICO offers shorter courses (two, three or four weeks) on invitation at a range of different countries. Visit

www.aravind.org/education/course-details.asp or write to Prof V Srinivasan, LAICO, 72, Kuruvikaran Salai, Gandhi Nagar, Madurai 625 020, Tamil Nadu, India.

Other resources

The **Eye Care Equipment Maintainers Discussion Group** is intended as a meeting point for people who use or maintain ophthalmic equipment or are interested in learning more. You can ask questions, share successes, or discuss any problems you are having with your ophthalmic equipment. Visit <http://groups.google.com/group/eye-care-equipment-maintainers> to join in.

Visit the **World Health Organization site** <http://who.ceb.unicamp.br/> for an up-to-date list of the available training units for biomedical equipment technicians and clinical engineers worldwide. Requires a Flash plug-in.

The **Inter Agency Procurement Group (IAPG)** is a forum for international non-government organisations to share logistical information and procedures; it meets every quarter. Visit www.iapg.org.uk for more information.

Suppliers

TALC (Teaching Aids at Low Cost):

PO Box 49, St Albans, Hertfordshire, AL 1 5TX, UK. Email: info@talcuk.org or visit www.talcuk.org

Aravind: Mail your order or enquiry to The Manager, Stores, Aravind Eye Hospital, 1, Anna Nagar, Madurai 625 020. Email stores@aravind.org or visit www.aravind.org/publications/catalogue.asp

How to look after and care for a slit lamp



Ismael Cordero

Senior Clinical Engineer, ORBIS International, 520 8th Avenue, 11th Floor, New York, NY 10018, USA.

The slit lamp is an essential and often-used diagnostic instrument in ophthalmology. It provides illumination and magnification for the examination of many structures of the anterior segment. With complementary lenses, it is also used to examine the chamber angle and a significant part of the retina. Its name derives from the fact that a narrow slit of light is used to illuminate the various structures being examined.

By following these simple suggestions, you can ensure that a slit lamp performs optimally and remains functional for longer.

Location

- Place the slit lamp where it is easily accessible to both staff and patients, some of whom may have physical disabilities.
- An electrical outlet should be available nearby and the power cord should not be in the path of staff or patients.
- The slit lamp should not be exposed to excessive temperature extremes, such as those produced by direct sunlight or air conditioning.
- The slit lamp should be kept in a dry environment since there could be fungal growth (mould or mildew) on the optical components if they are exposed to humidity (combined heat and moisture).

Spare parts

- Spare bulbs and fuses should be kept within easy reach in order to avoid delays in patient care.
- The minimum recommended stock of bulbs and fuses is two of each per slit lamp.
- When a part is used, it should be restocked immediately.

Replacing the bulb

- When handling or replacing a bulb, take care not to leave fingerprints on the bulb. Oil from your fingers can create hot spots on the bulb which will reduce its life. As a rule, handle bulbs with paper tissue or with cotton gloves.
- Check that you replace the bulb housing in the right position; otherwise the quality of the slit beam is compromised. Adjusting the position of the housing may correct a distorted beam.

Cleaning

- The slit lamp should be cleaned weekly, at a minimum, or more often if in a dusty environment.
- The slit lamp housing should be cleaned with a cloth that has been slightly

dampened with water. No other liquids or corrosive agents should be used.

- The exposed surfaces of the eyepiece optics (1) and the objective lens (2) should be cleaned using a soft optical dust brush. If, after being dusted, they still need additional cleaning, the lenses should then be wiped carefully with a lens cleaning cloth or with cotton swabs and lens cleaning solution.

Operational checks

The following functions should be checked **weekly**. The hospital's maintenance team or the service agent should be called if any problems are noticed during these checks.

- Brightness control: should noticeably vary the bulb's brightness.
- Table top movement: should move up and down freely.
- Chin rest adjustment (3): should move up and down freely.
- Joystick (4): should provide smooth motion up and down, forward and backward, and left and right.
- Slit controls: should smoothly vary the slit width (5), length (6), and inclination (6).
- Illumination rotation arm (7): should move smoothly and lock into position with the locking screw (8).
- Microscope rotation arm (9): should move smoothly and lock into position with the locking screw (10).
- Illumination tilting latch (11): should vary the illumination angle in stages.
- Filter changing knob (12): should change the filters.
- Magnification lever (13): should switch the magnification.
- The mechanism just behind the objectives that adjusts the pupillary distance (14) should move smoothly.

Other tips for care and maintenance

- If the clinic is subject to voltage fluctuations, the slit lamp should be plugged into a voltage stabiliser.
- When examining several patients in a row,

the illumination should be maintained at a low level rather than switching it off between patients and then on again for each patient. This prolongs the bulb's life.

- Moving the slit lamp should be avoided when the bulb is hot because the hot filament is more likely to break.
- When not in use, the slit lamp should be covered with its plastic dust cover. If not provided, a simple cover can be made out of cloth – the thicker/denser the better.
- If the slit lamp is stored in an environment prone to humidity, keep a sachet of silica gel drying agent or fungicidal (anti-mould) pellets within the dust cover, or use a dehumidifier in the room.
- The forward and backward, and left and right movements of the slit lamp rely on the joystick (4), a rod (15) connecting the two geared wheels (16), and the two rails (17) which support the wheels. These mechanical devices may seize up and affect the smooth operation of the slit lamp. If this is the case, apply a light oil spray, such as WD40, to a piece of paper tissue and use the tissue to wipe the rod, the pad under the joystick (18), the wheels, and the rails. This should solve the problem. Oil should never be sprayed directly onto these parts.

Figure 1: Diagram of a Haag-Streit style slit lamp

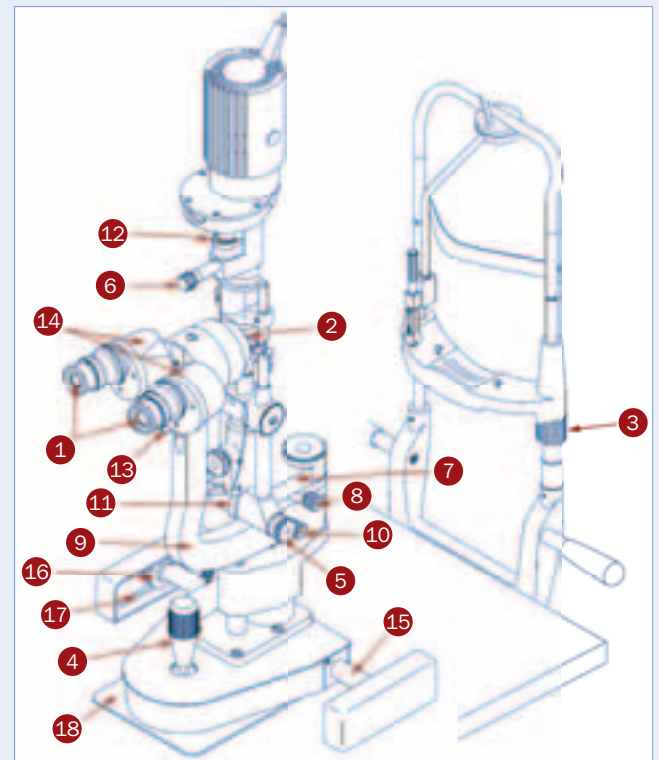

New series

This is the first installment in a series on practical equipment care, maintenance, and repair.

Ten years left to eliminate blinding trachoma

Danny Haddad

Director, International Trachoma Initiative, 325 Swanton Way, Decatur, GA 30030 USA.

In 1997, the World Health Organization formed the Global Alliance to Eliminate Blinding Trachoma by 2020 (GET 2020), a coalition of governmental, non-governmental, research, and pharmaceutical partners. In 1998, the World Health Assembly urged member states to map blinding trachoma in endemic areas, implement the SAFE strategy (which stands for surgery for trichiasis, antibiotics, facial-cleanliness and environmental change, such as clean water and latrines) and collaborate with the global alliance in its work to eliminate blinding trachoma.

Over these past 13 years, much progress has been made. Pfizer Inc has committed to donating the Zithromax necessary for eliminating blinding trachoma by 2020, non-governmental organisations have scaled up their support to national programmes to implement the SAFE strategy, and some trachoma-endemic countries are now close to reaching their intervention goals. Since the Pfizer donation began in 1999 through the International Trachoma Initiative (ITI), more than 155 million Zithromax treatments have been distributed.

But trachoma remains a blinding scourge. It is still believed to be endemic in 57 countries (Figure 1). Globally, 1.2 billion people live in trachoma-endemic areas, primarily in the poorest communities in low- and middle-income countries. Nearly 41 million people, mostly women and children, have active trachoma and could benefit from treatment. An estimated 8.2 million already have trichiasis, the end stage of the disease, and are at risk of becoming blind or visually impaired.

Figure 1. Trachoma-endemic countries



Source: Mariotti SP, Pascolini D, Rose-Nussbaumer J, "Trachoma: global magnitude of a preventable cause of blindness," *British Journal of Ophthalmology* 2009;93: 563-568

Copyright © 2010 Danny Haddad. This is an open access article distributed under the Creative Commons Attribution License, which permits unrestricted use, distribution, and reproduction in any medium for non-profit purposes, provided the original work is properly cited.

We only have ten years left to reach the goal of eliminating blinding trachoma. In order to achieve this, all endemic countries must have the full scale SAFE strategy in place by 2015 to allow enough time for implementation to have an impact. Enormous challenges lie ahead of us. Some of the remaining endemic countries are in conflict or have just come out of conflict, and lack infrastructure and resources to fully address the disease. Even countries free of conflict lack financial resources for the epidemiological surveys to determine which districts need intervention, or to support intervention in endemic districts. Implementing the SAFE strategy can be a strain on resources as well, since providing access to clean water and latrines is not inexpensive.

However, we believe that, together, we can overcome these challenges and reach our goal.

In this issue of the *Community Eye Health Journal*, a series of articles begins on blinding trachoma, which has incapacitated families and communities for centuries in nearly every corner of the world. The goal of this series is to explore what is new in the campaign to eliminate the disease, including recent developments in trichiasis surgery, mass drug administration, and cost-effective ways to improve sanitation and hygiene. Previous editions of the *Community Eye Health Journal* that focused on trachoma (editions 32 and 52) remain important resources for trachoma.

The first article in the series is about national trachoma task forces. We hope that this new series will provide tools to assist those who are implementing programmes to eliminate blinding trachoma.



Robert Essey/ International Trachoma Initiative

Mass distribution of antibiotics is one of the four components of the SAFE strategy. ETHIOPIA

National trachoma task forces: how can we work better?

Paul Courtright

pcourtright@kcco.net

Emmanuel Miri

emmamiri@yahoo.com

Tackling trachoma is a complex challenge.

In order to implement all four components of the SAFE strategy on a national level (surgery for trichiasis, antibiotics, facial cleanliness and environmental change, such as clean water and latrines), there needs to be national coordination, supported by political commitment at the highest level. In each trachoma-endemic country, the body responsible for making this work is the national trachoma task force (NTTF).

The NTTF consists of government representatives, NGOs, donors, academic institutions, and other stakeholders. In practical terms, the work of the NTTF involves:

- Devising a national plan for tackling trachoma that addresses each of the four components of the SAFE strategy and which is based on evidence and technical know-how. Setting national targets and timeline activities for the plan
- Planning and managing different activities within the national plan
- Bringing together the different groups needed to make the national plan work (government, NGOs, donors, etc.); ensuring good communication and trust between the groups and ensuring that everyone has realistic expectations
- Coordinating operational research on trachoma
- Monitoring and evaluating the successes of, and challenges faced by, the national plan, and revising the plan as needed
- Sharing information about the ongoing progress of the national plan with everyone involved, including the public.

Of vital importance to the success of an NTTF is the extent to which it can foster high-level political commitment from the national government.

Simply having a government representative on the NTTF is not enough. These individuals must be 'doers' – people who take

an active interest and are willing to act and lobby their peers in government on behalf of the NTTF. The reality is that there is always going to be competition within government departments, and between departments, for limited budgets. The NTTF needs to have strong political – and financial – support from within government. The following may help:

- Invite the national director of public health (or a similarly high-level government official) to join the leadership of the NTTF.
- Use visits by experts or other key international leaders as an opportunity to organise meetings with potentially helpful government officials.

Once political commitment to the national plan and the NTTF is achieved, the next goal is for this to be sustained in the long term. This is best achieved by putting systems and processes in place that will ensure that trachoma prevention becomes part of the regular business of government.

Consider doing some or all of the following on a regular basis:

- Develop a trachoma “organogram” showing the various partners (including government) and their activities in the country.
- Provide frequent and professional reports of meetings.
- Disseminate reports, updates, and fact sheets to key government officials on a regular basis.
- Regularly review the current trachoma knowledge base.
- Reach consensus with partners and all districts on how to report on trachoma data or develop a harmonised management information system (MIS) for trachoma in the country.
- Jointly celebrate achievements or special dates – share the credit for tasks accomplished.
- Organise routine meetings with specific government officials; the meetings should include a cross-section of members of the NTTF.
- Share with government feedback from international meetings that one or more NTTF members have attended.

Having a strong, well-functioning, and collaborative NTTF will assist trachoma-endemic countries in sub-Saharan Africa to realise their goal of eliminating blinding trachoma. An NTTF will not achieve this without specific investments in capacity building in the areas of leadership, partnership, management, and political ownership. Make use of every opportunity to build skills in these areas, whether through formal courses or informal sessions during NTTF meetings.

Investments made now will reap benefits beyond the time when trachoma ceases to be a public health problem.

Copyright © 2010 Paul Courtright and Emmanuel Miri. This is an open access article distributed under the Creative Commons Attribution License, which permits unrestricted use, distribution, and reproduction in any medium for non-profit purposes, provided the original work is properly cited.



CPD: Test yourself

Continuing Professional Development (CPD), also known as Continuing Medical Education (CME), describes courses and activities which help professionals such as health care workers to broaden their knowledge and improve their skills.

Through this **CPD Test yourself section**, we aim to support your continued professional development. We hope that you will use these questions to test your own knowledge and understanding, and that you will discuss them with your colleagues and other members of the eye care team.

These questions have been developed in association with the International Council of Ophthalmology and are based on the style of the ICO Advanced Examination www.icoexams.org/exams/advanced

1. Think about the responsibilities of eye care workers for the care and maintenance of equipment. Which of the following statements are true and which are false?		True	False
a	It is better to wait no more than one week before reporting a fault with your equipment	<input type="checkbox"/>	<input type="checkbox"/>
b	Equipment users are responsible for checking the safety of their equipment	<input type="checkbox"/>	<input type="checkbox"/>
c	Equipment that is being taken out of use (decommissioned) can be disposed of along with other waste	<input type="checkbox"/>	<input type="checkbox"/>
d	Only junior equipment users are responsible for looking after the equipment they use	<input type="checkbox"/>	<input type="checkbox"/>
2. Think about the practical aspects of equipment maintenance and repair. Which of the following statements are true and which are false?		True	False
a	Because of their design, it does not matter if foot pedals get wet	<input type="checkbox"/>	<input type="checkbox"/>
b	A voltage stabiliser or regulator cannot always prevent damage to equipment	<input type="checkbox"/>	<input type="checkbox"/>
c	You should take bulbs, screwdrivers, and fuses along when going on outreach	<input type="checkbox"/>	<input type="checkbox"/>
d	There is nothing you can do to prevent fungal growth (mould) forming on optical components	<input type="checkbox"/>	<input type="checkbox"/>
3. Think about equipment donations and purchasing equipment		True	False
a	When purchasing equipment, order enough spare parts and consumables for at least two months	<input type="checkbox"/>	<input type="checkbox"/>
b	You should always accept donated equipment when it is offered	<input type="checkbox"/>	<input type="checkbox"/>
c	Delays in clearing equipment through customs can end up increasing your costs	<input type="checkbox"/>	<input type="checkbox"/>
d	Budget and plan for maintenance and repair as soon as the equipment arrives	<input type="checkbox"/>	<input type="checkbox"/>
4. Think about training for equipment maintenance and repair		True	False
a	A highly competitive environment helps equipment users learn better	<input type="checkbox"/>	<input type="checkbox"/>
b	Formal courses are the only appropriate way of training the equipment maintenance and repair team	<input type="checkbox"/>	<input type="checkbox"/>
c	The service manual can be very useful in isolated eye units	<input type="checkbox"/>	<input type="checkbox"/>
d	Even with an in-house workshop, there will always be a need for outsourced maintenance services	<input type="checkbox"/>	<input type="checkbox"/>

ANSWERS

1. a. False. Faults should be reported immediately. b. True c. False. Some equipment may contain hazardous materials. d. False. All equipment users are responsible and should be trained to use and care for their equipment properly.
2. a. False. Moisture can cause the electrical components to stop working. Always lift off the floor when the floor is being cleaned. b. True. Even the best voltage stabiliser cannot prevent all possible damage due to fluctuations in electricity. However, good quality stabilisers will offer better protection. c. True. d. False. For example, you can place fungicidal (anti-mould) pellets or sachets of silica gel drying agents inside the dust cover, or use dehumidifiers to keep the room dry.
3. a. False. Order enough for one year, or more if spare parts are difficult to obtain. b. False. Ensure you have the skills, resources and budget needed to use and care for the equipment. There may also be shipping or customs clearance costs. c. True. The shipping company will charge more if they have to store the equipment for a longer time. d. False. This might be too late – maintenance and repair services may be unaffordable or not available locally. Rather budget and plan at the time of purchase or before.
4. a. False. A friendly environment is better for teaching equipment users. b. False. Work placements (internships) and on-the-job training are just two of the many other ways to train these workers. c. True. The service manual contains more detailed information than the user manual. At the time of purchase, try to obtain the service manual from the supplier. d. True. Some tasks are too complex for the in-house team.



Two losses for eye care

We are sad to report the deaths of Drs Moses Chirambo and Tom Little in recent months.



Moses Chirambo was Malawi's first ophthalmologist and was later appointed minister of health for his country. He passed away on August 14 during medical treatment in South Africa. Dr Chirambo worked for Sightsavers as Eye Care Programme Consultant for the East, Central, and Southern African Region; he also established and ran the Southern African Development Community (SADC) ophthalmologist course at the Malawi College of Health Sciences. He pioneered Malawi's first eye training school in the capital Lilongwe and helped establish similar programmes in Botswana, Namibia, Zimbabwe, and Zambia.



Tom Little, an optometrist from New York, was killed during outreach work in Nuristan province, Afghanistan, on 6 August. Dr Little had worked in eye care in Afghanistan for thirty years and supervised a network of eye hospitals around the country. At the time of his death, he was leading a team of nurses, doctors, and logistics personnel providing specialist eye treatment and health care to people in remote communities.

Have you got news for us?

We would like to hear from you about new developments in eye care in your country or region. You can also let us know if you have meetings, courses, or events you would like to announce in the journal. Write to The Editor, International Centre for Eye Health, London School of Hygiene & Tropical Medicine, Keppel Street, London, WC1E 7HT, UK or email editor@cehjournal.org

Get your own copy

Do you live in a low- or middle-income country? Did you know you can get your own, free copy of this journal, delivered **free** to your home address?

All you have to do is send your name, occupation, and postal address to Anita Shah, International Centre for Eye Health, London School of Hygiene & Tropical Medicine,

Video and photo competition

What does the *Community Eye Health Journal* mean to you? Send us a photograph or short video showing how you use the journal in your daily work – whether to teach others, to refresh your knowledge, or to improve the lives of patients. The overall winner will receive Kanski's *Clinical Ophthalmology*, kindly donated by Elsevier (worth UK £164).

Extended deadline: 1 March 2011. **Patient permission:** if your photograph or video shows any patients, you must get their written permission and include this in your entry. **Send to:** The Editor, *Community Eye Health Journal*, International Centre for Eye Health, London School of Hygiene and Tropical Medicine, Keppel Street, London WC1E 7HT, UK, or email editor@cehjournal.org More information: www.cehjournal.org/competition



Keppel Street, London, WC1E 7HT, UK, or email her on Anita.Shah@Lshstm.ac.uk

This journal is for **all health workers with eye care responsibilities**, whether you are a nurse, community health worker, medical doctor or specialist ophthalmologist. If you know of anyone else who will benefit from reading this journal, please tell them how easy it is to subscribe, or send their details directly to us.

Erratum

The answer to our CPD question 1D (page 19 of Issue 72) should be FALSE. There is in fact a great deal that can and must be done for a blind infant by specialist instructors (specialised occupational therapists and early intervention specialists for the visually impaired) to support both the infant and the infant's family. We hope that you spotted the error and apologise for any confusion.

Meetings

Access Africa: The 5th Institutional Development Programme (IDP) Africa Forum, Ghana Institute of Management and Public Administration, July 3-8, 2011. Themes include technology, access, and social and economic empowerment for people who are blind or partially sighted. For more information, email africaforum2011@gmail.com or write to Aubrey Webson, c/o Perkins International, 175 North Beacon Street, Watertown, MA 02472 USA.

Courses

Lions Aravind Institute of Community Ophthalmology (LAICO) LAICO offers **instrument maintenance courses** with a trainee:trainer ratio of 1:1.

Four courses take place in 2011, starting on 1 February, 1 May, 1 August, and 1 November respectively. Duration: six weeks per course. Cost: US \$400 (including tools). Location: LAICO, Aravind Eye Care Systems, Madurai, India. Visit www.aravind.org/education/coursedetails.asp for more information or write to Prof V Srinivasan, LAICO, 72, Kuruvikaran Salai, Gandhi Nagar, Madurai 625 020, Tamil Nadu, India. Email: v.srinivasan@aravind.org

Kilimanjaro Centre for Community Ophthalmology (KCCO)

All courses held in Moshi, Tanzania. For information, contact Genes Mng'anya, KCCO, Good Samaritan Foundation, P.O. Box 2254 Moshi, Tanzania, Tel +255 27 275 3547. Email: genes@kcco.net or visit www.kcco.net

Bridging communities and eye care providers to achieve VISION 2020 in Africa: 8-12 November 2010

Management for VISION 2020 programme managers: 15-26 November 2010

Writing a research manuscript: 29 November to 3 December 2010

Community Eye Health Institute, South Africa

Certificate course in community eye health. Aim: to provide training in the management of district VISION 2020 programmes. Start date: February 2011. Duration: 10 weeks. Cost: ZA R16,500 (approximately US \$2,400) plus living expenses in Cape Town. Email cehi@uct.ac.za or write to Community Eye Health Institute, University of Cape Town, Private Bag 3, Rondebosch, 7700, South Africa.

Community Eye Health JOURNAL

Supported by:



cbm
community eye health



ORBIS
saving sight worldwide



foundation
DARK & LIGHT



LIONS WORKGROUP FOR THE BLIND
THE NETHERLANDS



Sightsavers



The Fred Hollows
Foundation

Next issue



Lutful Husain

The next issue of the *Community Eye Health Journal* will be on **VISION 2020: why information matters**